



VARISPEED STRAIGHT KNIFE

MACHINE SERIAL NO. _____
DATE OF PURCHASE ____/____/____

INSTRUCTIONS & PARTS LIST

120V: Model VS1-8 (From December 1995, Serial No. AF13-A6L-27825 up)

220V: Model VS2-8 (From August 1995, Serial No. AF43-A6M-27469 up)

EDITION 2.8

NOTE: These pages are a supplement to Maimin Straight Knife Instructions and Parts Lists (Model A). Refer to those lists for all information not included in this supplement. In particular, read SAFETY INSTRUCTIONS carefully.

Book #22155

H. MAIMIN CO., INC., P.O. BOX 549, ROUTE 341, KENT, CT 06757 USA

TEL: 860-927-4600 USA: 800-243-4645 FAX: 860-927-4703
From the library of: Superior Sewing Machine & Supply LLC

PRINTED IN USA

g:\apps\works\1995\varispd.wps

IMPORTANT SAFETY INSTRUCTIONS

When using your cutting machine, basic safety instructions should always be followed including the following:

This cutting machine is for commercial use only. Read all instructions before using.

DANGER--to reduce the risk of electric shock:

1. Do not install or store this machine in a wet location.

WARNING--to reduce the risk of burns, fire, electric shock, or injury to persons:

1. Use machine only for its intended use as a portable cutting machine.
2. Turn machine to "OFF"(O) before connecting or disconnecting power cord.
3. Connect this machine to a properly grounded outlet only. See Grounding Instructions.
4. Always disconnect electrical connector from machine when not using it, before servicing it, or changing blade.
5. Do not leave machine unattended while it is connected to power outlet.
6. Do not operate machine with a damaged cord or if machine has been dropped. Do not disassemble -- take to a qualified serviceman for repairs. Incorrect assembly can cause electric shock when the machine is used.
7. Keep hands and fingers away from blade and moving parts.
8. Keep guards in place and in working order,
9. The knife key and other wrenches must be removed from machine before starting the motor.
10. Keep ventilation openings of machine free from dust and lint.
11. Keep machine clean and blade sharp for best and safest performance.

SAVE THESE INSTRUCTIONS

GROUNDING INSTRUCTIONS

This machine must be grounded. In the event of malfunction or breakdown, grounding provides a path of least resistance for electric current to reduce the risk of electric shock. This machine is equipped with a Ground Shield surrounding the Terminal Pins; this Ground Shield is designed to be used with a Maimin Grounded Connector, part #458A or 458B. See Wiring instructions supplied with the Connector.

DANGER -- Improper connection of the Maimin Connector can result in a risk of electric shock. Check with a qualified electrician or service man if the grounding instructions are not completely understood or if in doubt as to whether the machine is properly grounded.

Do not modify the Ground Shield provided with this machine.

Use correct wire sizes with the Maimin Grounded Connector.

U.S.A. only: 1 Phase: Use AWG 16/3 SJ, SJT or SJE
3 Phase: Use AWG 16/4 SJ, SJT or SJE

International: 1 P+N+: Use 3X1, 0mm CEE (2) 61
3 P+: Use 4X1, 0mm CEE (2) 61

OPERATING INSTRUCTIONS

TO START

1. Oil crosshead at oil cup.
2. Attach connector to terminal pins.
3. Move switch from "0" to "1".

TO SHARPEN BLADE

A. 120V MOTOR:

1. Remove machine from material.
2. Lower presserfoot leg to baseplate.
3. Move switch from position "1" to "2" and hold in this position.
4. Pull sharpener trigger and release it.
5. When sharpening cycle is complete, release switch. It will return to position "1".

B: 220V MOTOR:

1. Remove machine from material.
2. Lower presserfoot leg to baseplate.
3. Push pushbutton gently and hold in this position.
4. When sharpening cycle is complete, release pushbutton

VARISPEED MOTOR INSTRUCTIONS AND PARTS LIST

1. DESCRIPTION

The MAIMIN VARISPEED is designed to operate on AC current. It has a direct current motor with a permanent magnet field, controlled by an adjustable speed SCR drive.

2. VOLTAGE CONNECTION

Connect only to voltage shown on nameplate.

3. NAMEPLATE RATINGS

Values are for full load conditions.

Do not use motor for prolonged periods at line currents greater than shown on nameplate.

4. OVERLOAD PROTECTION

The control box is fused with a time-delay ceramic-tube fuse; 8 AMP for 120V, 5 AMP for 220V. Do not use a larger fuse without consulting Maimin.

5. MOTOR ROTATION

Remove button plug (Part 446Q) from back of housing (Part 15235).

Correct rotation is counter-clockwise looking at end of armature. (Bands must rotate away from blade.) If motor rotates in wrong direction, change by reversing black and white wires on control

6. SLOW START

Your control is equipped with a circuit for slow starting and controlled acceleration. The short delay between the time you turn on the machine and it reaches set speed is normal.

7. MAGNETS

Avoid dropping or shaking blows to motor. Demagnetize coils only with severe overvoltage. (About 150% normal). Magnets can only be purchased as part of a magnet and shell assembly.

8. **BRUSHES**

Brushes (Part 15237) should be inspected periodically to insure uninterrupted service. Length of new brush is 1.250" (31.75 mm). Minimum operating length is 0.500" (12.7 mm). Life depends on speed and load. We suggest inspection brushes every 1000 hours.

TO INSPECT BRUSHES:

Remove brush cover (Part 15238) and insulator (Part 15239). Depress brush clip (Part 15241) so as to disengage tabs of clip and remove. Remove roll spring (Part 15240). Loosen Phillips pan head screw, remove lug and withdraw brush (Part 15237).

9. **MOTOR BEARINGS**

Bearings are lubricated for life. Rear motor bearing (Part 403) can be replaced by removing four 8-32 keep-nuts (Part 857N) and back housing (Part 15235). Using bearing puller, pull bearing off armature shaft. To remove front bearing, motor must be disassembled. See Motor Disassembly. After motor is separated from front housing, pull bearing off armature shaft using bearing puller.

10. **MOTOR DISASSEMBLY**

In order to disassemble motor, the crank must be removed. Remove sharpener and connecting rod. Insert handle of knife key into hole in face of crank and tap clockwise until crank loosens on armature. Disconnect two armature leads (A+ & A-) from control on box (Part 447Z). Remove nut for strain relief (Part 465K) and remove cable with quick disconnects. To remove back housing (Part 15235) from shell and magnet assembly remove four 8-32 kep-nuts (Part 857N).

Pull brushes (Part 15237) out and away from commutator so as not to damage them when pulling armature from shell and magnet assembly (Part 15354).

With rubber or plastic headed hammer tap end of armature until complete motor separates from front housing

CAUTION; Do not lose wave washer (Part 15195) at back housing.

11. **MOTOR ASSEMBLY**

CAUTION: Avoid pinching your fingers and scarring commutator or wires. Slide commutator end of armature through magnets by using the edge of the ball bearing to guide start of insertion.

TROUBLE -SHOOTING GUIDE

Symptom	Possible Cause	Actions to Correct
Motor does not run, Lamp off	<ol style="list-style-type: none"> 1. Blown fuse 2. Defective switch 3. Wrong voltage 	<ol style="list-style-type: none"> 1. Replace fuse. 2. Replace switch. 3. Connect only to voltage shown on nameplate.
Motor does not run, Lamp on	<ol style="list-style-type: none"> 1. Worn brushes 2. Loose connection 3. Defective control 	<ol style="list-style-type: none"> 1. Replace. 2. Remove cover with control attached. Check all 7 connections on control. 3. Using a DC Volt meter; volts from -A to +A should be 90V or 180V when speed control is at "10"; Adjust trim pot to desired speed.
Motor top speed is too slow or too fast	<ol style="list-style-type: none"> 1. Under voltage or over voltage 2. Wrong setting of control 	<ol style="list-style-type: none"> 1. & 2. Remove cover with control from box. Set knob at "100"; Adjust MAX trim pot at desired speed. Set knob at "10"; Adjust trim pot to desired speed.
Motor stalls when cutting	<ol style="list-style-type: none"> 1. Worn brushes 2. Loose connections 3. Overload 	<ol style="list-style-type: none"> 1. Replace. 2. Check all connections. 3. Current limit has been set at factory. Limit can be raised by adjusting CL clockwise.
Motor runs at set speed but does not speed up with push button or on position "2" for 120V only	<ol style="list-style-type: none"> 1. Defective pushbutton 443J (for 220V only) 2. Defective switch 443H (for 120V only) 	<ol style="list-style-type: none"> 1. & 2. Replace.
Motor "Cogs" (pulsing or irregular rotation)	<ol style="list-style-type: none"> 1. Too much IR compensation 2. Dust from carbon brushes 	<ol style="list-style-type: none"> 1. Adjust IR counter clock-wise 30 at a time until cogging stops. 2. Remove dust from rear housing with compressed air.
"Sparking" at rear of motor.	<ol style="list-style-type: none"> 1. Dust from carbon brushes 	<ol style="list-style-type: none"> 1. Remove dust from rear housing with compressed air.
Repeated fuse blowing	<ol style="list-style-type: none"> 1. Low voltage 2. Loose connections 3. Worn brushes 4. Defective electronic components 	<ol style="list-style-type: none"> 1. Check input-should be at least 100V or 218V AC. 2. Check all connections. 3. Replace 4. Replace control.

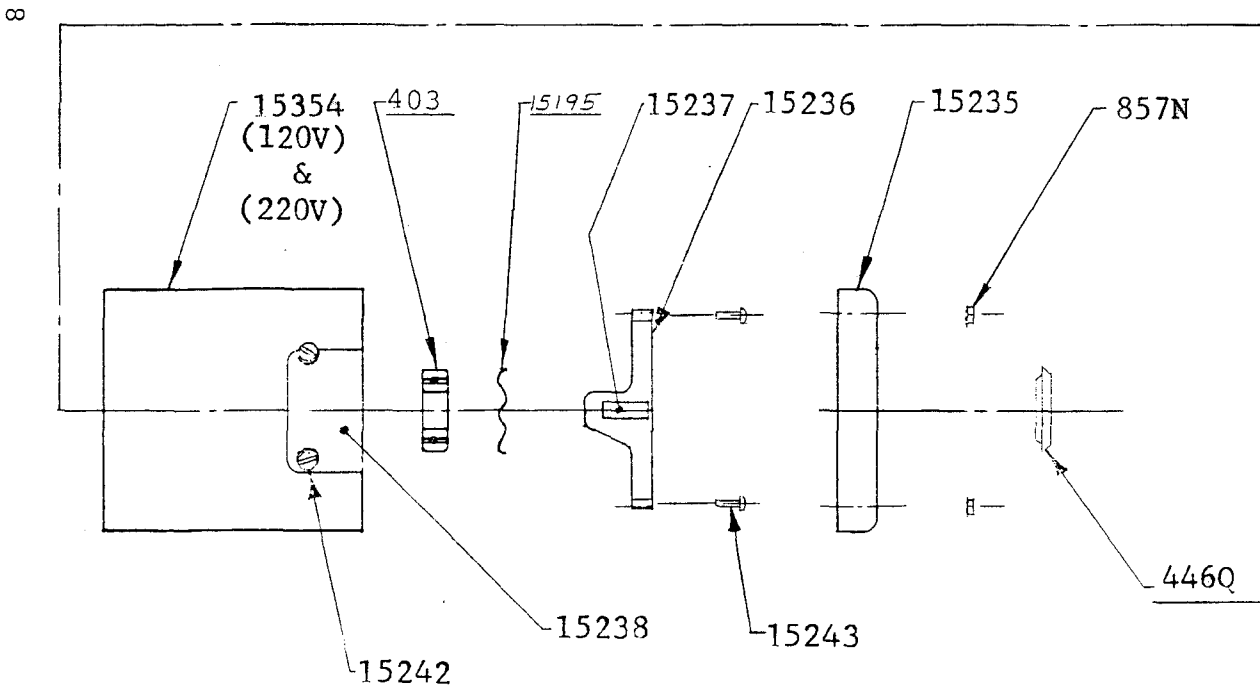
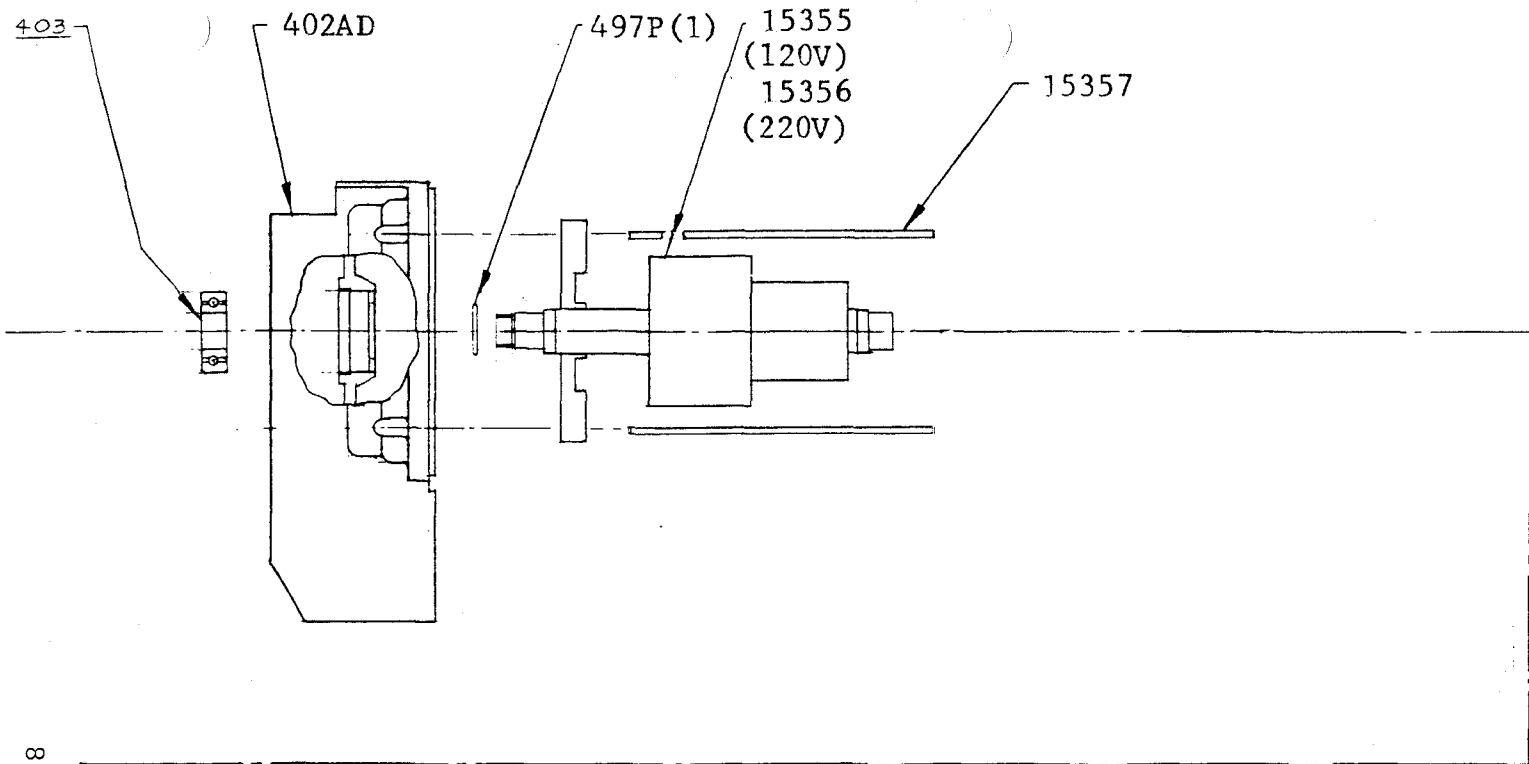

15345 120V
 15346 220V

PARTS LIST - MOTOR SECTION OF VARISPEED

(For parts not shown refer to Straight Knife Parts & Instructions Book)

PART NO.		DESCRIPTION
120V	220V	
VS1-8	VS2-8	
402AD	402AD	Front Housing Only VS-8
403	403	Bearing, Front & Rear
443H	443A	Switch
	443J	Pushbutton Switch
444B	444B	Cable Clamp (3)
446P	446P	Screw 8-32 X 1/4 Button Hd. Soc (3)
446Q	446Q	Hole Plug
468A	468A	Thumbwheel Assembly
468S	468S	Screw 6-32 X 7/8 Soc Hd Cap (2)
483E	483E	Grommet
497P	497P	Support Washer
15195	15195	Wave Washer
15345	15346	Motor
15354	15354	Shell & Magnet Assembly
15355	15356	Armature
15235	15235	Back Housing
15236	15236	Brush Terminal Assembly
15237	15237	Brush (Ea)
15238	15238	Brush Cover (2)
15239	15239	Brush Cover Insulator (2)
15240	15240	Roll Spring (2)
15241	15241	Brush Clip (2)
15242	15242	Screw 8-32 X 3/8 PhillipsPan Hd (4)
15243	15243	Screw 10-32 X 1/2 PhillipsPan HD (4)
15357	15357	8-32 /x 7 15/16 Threaded Rod (4)

From the library of: Superior Sewing Machine & Supply LLC

(Part numbers refer to drawing 15345-15346 on next page)

PARTS LIST - CONTROL SECTION FOR VARISPEED

PART NO		DESCRIPTION
120V	220V	
<u>VS1-8</u>	<u>VS2-8</u>	
405VA	405VA	Terminal Block only
405D	405D	Terminal Block Assembly
446V	446V	Screw #4 X 3/16 Type Pan Hd.
444C	444M	Control
444SA	444SB	Fuse (8 AMP for 120V;5 AMP for 220V)
444U	444U	Knob & Dial Kit
444W	444W	Bracket
444X	444X	Bracket Cover
446F	446F	Potentiometer
688A	688B	Pilot Light
447G	447G	Fuse Holder
447N	447N	O-Ring
447Y	447Y	Cover
447Z	447Z	Box
465K	465K	Strain Relief

From the library of: Superior Sewing Machine & Supply LLC

ADJUST TRIM POTS IN THE FOLLOWING ORDER

(CLOCKWISE INCREASE)

- 1- IR COMP INCREASE UNTIL SPEED IS CONSTANT WITH INCREASING LOAD. TOO MUCH IR COMP CAUSES MOTOR TO HUNT.
- 2- SET MAX SPEED WHILE MANUAL KNOB IS AT MAXIMUM.
- 3- SET MIN SPEED WHILE MANUAL KNOB IS AT MINIMUM.
- 4- CURRENT LIMIT MAY BE INCREASED IF MOTOR STALLS.

TOLERANCE UNLESS STATED

H. MAIMIN CO., INC.

XXX ±		PART NAME SCHEMATIC FOR 444C CONTROL-120V		
XX ±	DFTM.GML	DATE 2-12-86	CHKR.	MATERIAL
ANGLES ±	DIMENSIONS IN INCHES - SCALE		HEAT TREAT.	

REVISIONS			
LTR.	DESCRIPTION	DATE	APP

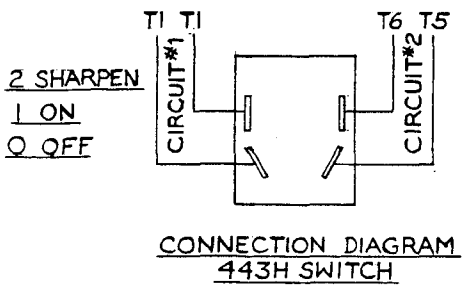
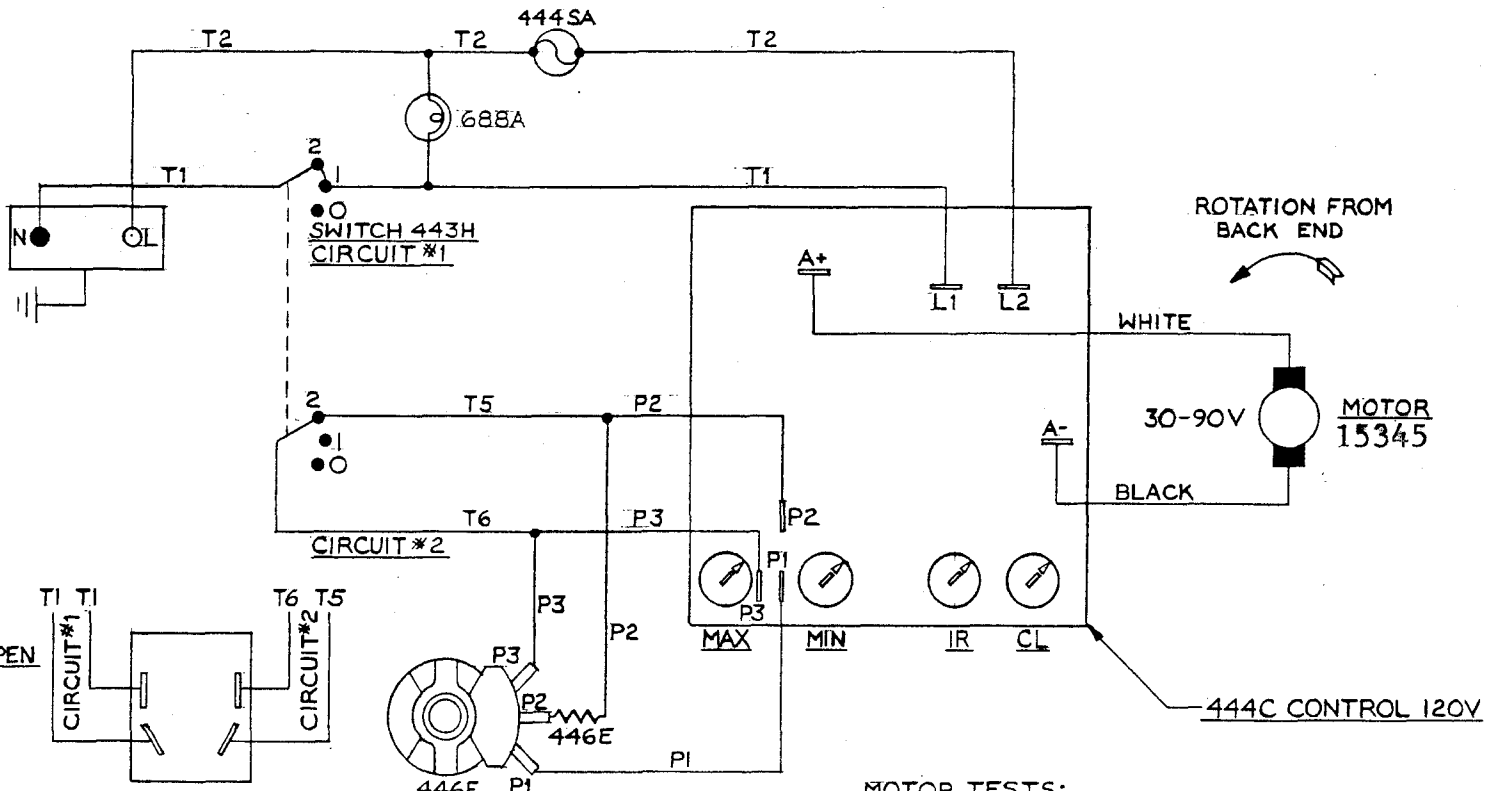
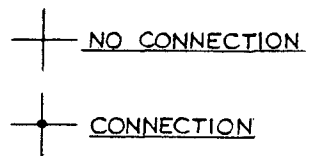

MOTOR TESTS:
 DISCONNECT BLACK & WHITE MOTOR LEADS FROM CIRCUIT BOARD.
 CONNECT MOTOR LEAD ENDS TOGETHER AND TEST TO GROUND.
 INSULATION STRENGTH 1500V-1 MIN.(CEE 20; 15.1)
 GROUND CONTINUITY(UL 73; 48.1)
 RESISTANCE BETWEEN BLACK & WHITE = 1.4 Ω

S-444M

- ADJUST TRIM POTS IN THE FOLLOWING ORDER.
 (CLOCKWISE INCREASE)
 1- IR COMP INCREASE UNTIL SPEED IS CONSTANT WITH INCREASING LOAD. TOO MUCH IR COMP CAUSES MOTOR TO HUNT.
 2- SET MAX SPEED WHILE MANUAL KNOB IS AT MAXIMUM.
 3- SET MIN SPEED WHILE MANUAL KNOB IS AT MINIMUM.
 4- CURRENT LIMIT MAY BE INCREASED IF MOTOR STALLS.

TOLERANCE UNLESS STATED		H. MAIMIN CO., INC.		
x x x ±	—	PART NAME SCHEMATIC FOR 444M CONTROL-220V		
x x ±	—	DFTM:GML	DATE 3-11-86	CHKR. _____
ANGLES ±	—	DIMENSIONS IN INCHES - SCALE ~		HEAT TREAT. _____

REVISIONS			
LTR.	DESCRIPTION	DATE	APP.

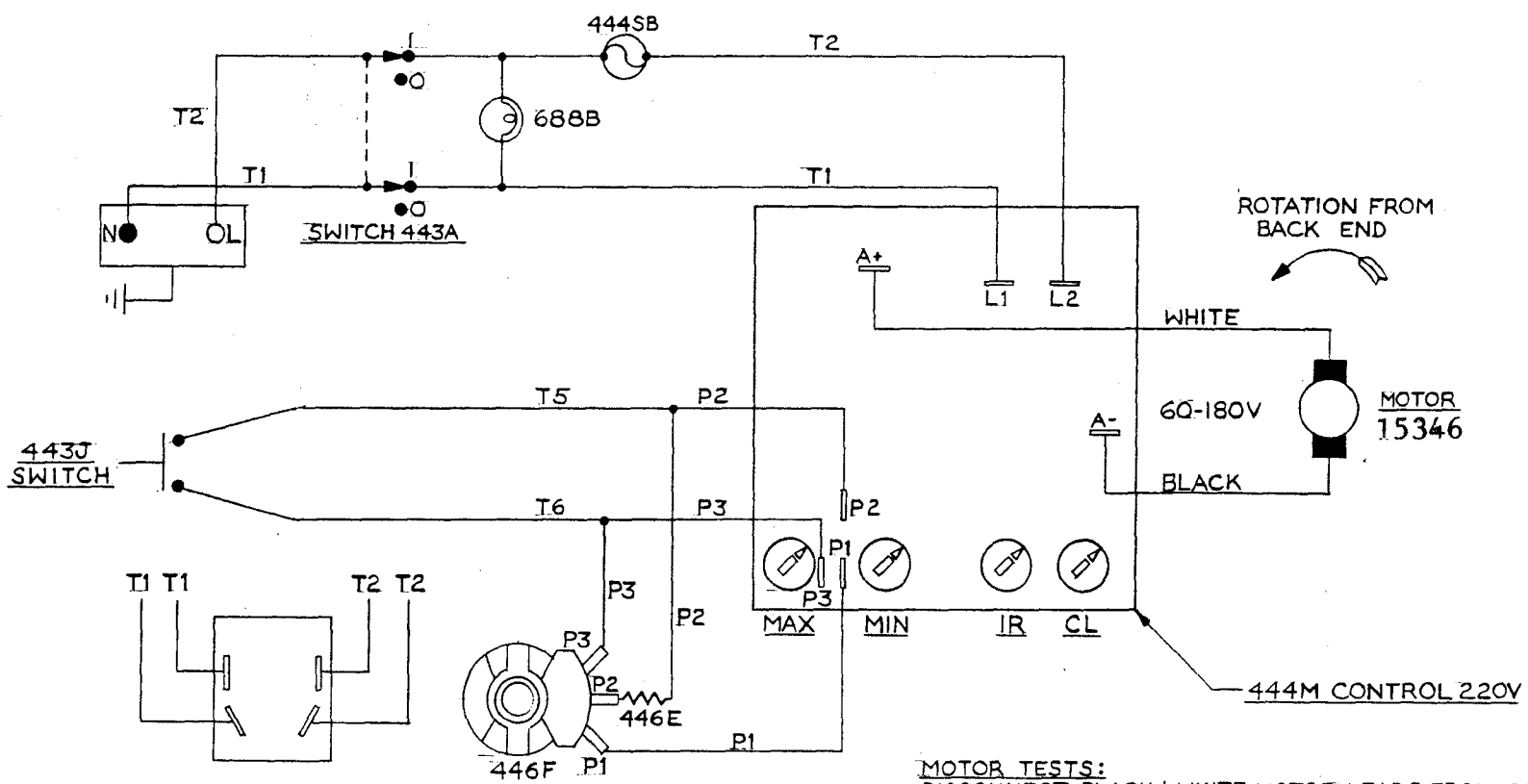
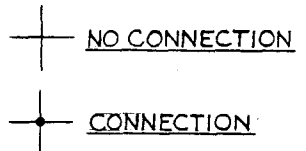

CONNECTION DIAGRAM
443A SWITCH

MOTOR TESTS:
 DISCONNECT BLACK & WHITE MOTOR LEADS FROM CIRCUIT BOARD.
 CONNECT MOTOR LEAD ENDS TOGETHER AND TEST TO GROUND.
 INSULATION STRENGTH 1500V-1MIN. (CEE 20; 15.1)
 GROUND CONTINUITY (UL 73; 48.1)
 RESISTANCE BETWEEN BLACK & WHITE=3.8 Ω

S-444M

MAIMIN[®]

Straight Knife Cutting Machine with Flexi-band Sharpener (Model A)

SABRE **3000**

SABRE **2000**

SABRE **1000**

Instruction and Parts List

**MACHINE
SERIAL NO.**

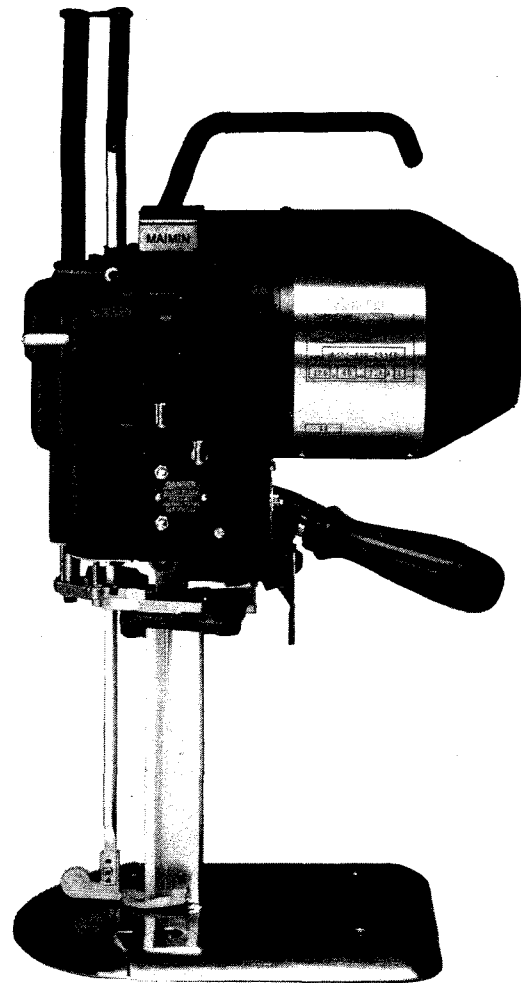

Edition 1.4

© 1993 H. MAIMIN CO., INC.

IMPORTANT SAFETY INSTRUCTIONS

When using your cutting machine, basic safety instructions should always be followed including the following:

This cutting machine is for commercial use only. Read all instructions before using.

DANGER—To reduce the risk of electric shock;

1. Do not install or store this machine in a wet location.

WARNING—To reduce the risk of burns, fire, electric shock, or injury to persons:

1. Use machine only for its intended use as a portable cutting machine.
2. Turn machine to "OFF" (O) before connecting or disconnecting power cord.
3. Connect this machine to a properly grounded outlet only. See Grounding Instructions.
4. Always disconnect electrical connector from machine when not using it, before servicing it, or changing blade.
5. Do not leave machine unattended while it is connected to power outlet.
6. Do not operate machine with a damaged cord or if machine has been dropped. Do not disassemble take to a qualified serviceman for repairs. Incorrect assembly can cause electric shock when the machine is used.
7. Keep hands and fingers away from blade and moving parts.
8. Keep guards in place and in working order.
9. The knife key and other wrenches must be removed from machine before starting motor.
10. Keep ventilation openings of machine free from dust and lint.
11. Keep machine clean and blade sharp for best and safest performance.

Save These Instructions

GROUNDING INSTRUCTIONS

This machine must be grounded. In the event of malfunction or breakdown, grounding provides a path of least resistance for electric current to reduce the risk of electric shock. This machine is equipped with a Ground Shield surrounding the Terminal Pins; this Ground Shield is designed to be used with a Maimin Grounded Connector, part number 458A or 458B. See wiring instructions supplied with the Connector.

DANGER—Improper connection of the Maimin Connector can result in a risk of electric shock. Check with a qualified electrician or serviceman if the grounding instructions are not completely understood or if in doubt as to whether the machine is properly grounded.

Do not modify the Ground Shield provided with this machine.

Use correct wire sizes with the Maimin Grounded Connector.

U.S.A. ONLY: 1 phase: Use AWG16/3 SJ, SJT or SJE
3 phase: Use AWG 16/4 SJ, SJT or SJE

INTERNATIONAL; 1P+N+: Use 3 x 1, 0 mm CEE (2) 61
3P+: Use 4 x 1, 0 mm CEE (2) 61

I. DESCRIPTION

1.1 GENERAL

Your new Maimin Sabre straight knife machine is delivered ready for operation. It is merely necessary to connect it to an electrical outlet of the correct voltage, oil it, and then begin cutting. The straight knife machine can be used for cutting various types of materials from a few ply to the full capacity of the machine. However, for best results, it is recommended that the minimum height of the lay be no lower than the bottom of the cutting blade at its highest position. The Presserfoot Leg (Key No. A403) acts as a protective guard for the operator so that it should be down at all times. The Presserfoot should lie lightly on top of the lay when cutting in order to prevent the material from vibrating.

1.2 FLEXIBANDS AVAILABLE

Three different grits of "FlexiBands" are available for sharpening the blade:

Coarse — For hard or coarse materials
(Part 1450 — Box of 100)
(Part 1457 — Box of 500)

Medium — For fine woollens, synthetics and cottons
(Part 1451 — Box of 100)
(Part 1458 — Box of 500)

Fine — For sheer fabrics, very soft materials
(Part 1452 — Box of 100)
(Part 1459 — Box of 500)

1.3 BLADES AVAILABLE

The blades come in three grades and in different shapes for cutting unusual or difficult materials. The three grades available are:

ZK — High Speed Steel...Most popular blade as it wears well retaining its cutting edge for a long time.

BK — Carbon Alloy Steel... A quality blade less durable than the ZK blade but less costly.

TK — Treated High Speed Steel...Retains cutting edge very well. Used only for hard or abrasive materials such as fiberglass or heavy denim as it is very expensive.

See back cover for complete list of part numbers of blades according to size, grade, shape, and quantity.

II. OPERATION

2.1 UNPACKING A NEW MACHINE

During shipment oil may have flowed onto Pulley A303 which can cause sharpener to traverse slowly. Sharpener cycle time is 1.5 seconds. If longer, oil is causing Pulley to slip. To remove oil, disconnect power, remove Brake A342, wipe oil from Pulley and Crank A505. Replace Brake.

2.2 TO START

Fill oil cups. Attach Connector A525 to Terminal Pins A523. Move switch A550 from "off" to "on" (USA) or "O" to "I" (International).

Caution: 3 phase motor must turn counter-clockwise when viewed from rear. (FlexiBand against Blade must rotate from back to front).

2.3 TO SHARPEN BLADE (Figure 1)

Machine should be clear of lay and Presserfoot "A" should be down on Baseplate "B". With motor running, move Tripper Handle "C" to right (facing sharpener) until it latches. Release it. Sharpener will automatically sharpen entire blade. Repeat if necessary.

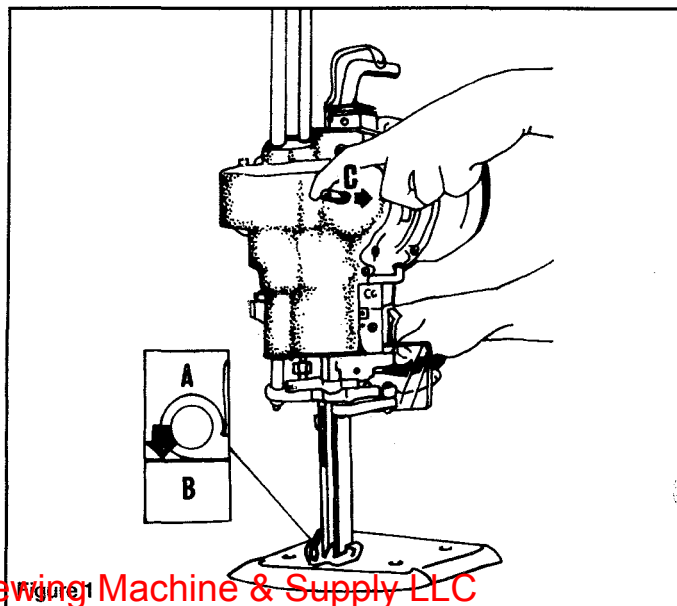

2.4 TO CUT

Raise Presserfoot A402 above top of lay by pressing down on Presserfoot Handle A323 and lifting Presserfoot Lift. For Squeeze Trigger, pull Handle 23308 towards machine Handle A549. Enter lay, and lower Presserfoot to top of lay by releasing Presserfoot Trigger. When making turns in lay, it is sometimes advisable to let Presserfoot ride freely on top of lay by pushing down on Presserfoot Handle. When machine is not in use, always lower Presserfoot to Baseplate. The Presserfoot Leg acts as a safety guard for the blade.

2.5 TO CHANGE FLEXIBANDS (Figures 2 and 3)

- Disconnect power.
- Figure 2: Push Block "A" to release right (upper) FlexiBand "B". Remove FlexiBand from Block and then from Drive Pulley "C".
- Figure 3: Slip new FlexiBand "B" over Drive Pulley "C" and between Band Plate "D" and Blade "E." Push Block "A" forward and slide FlexiBand over it. Release Block "A."
- Remove left (lower) FlexiBand, and install new one in same manner.

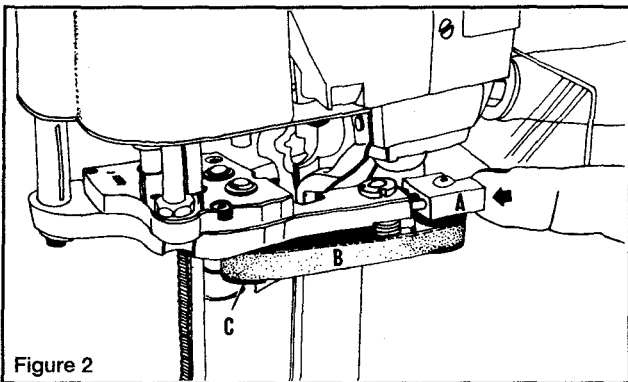

Figure 2

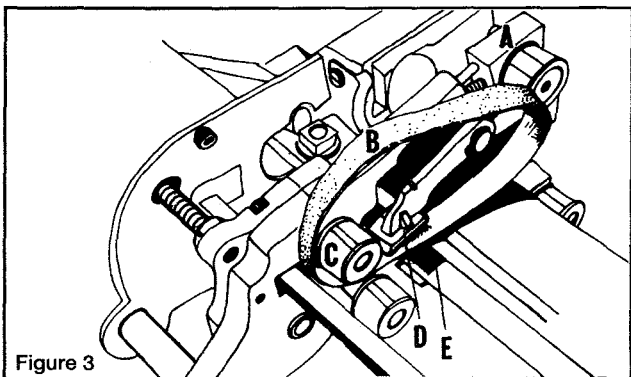

Figure 3

2.6 TO CHANGE BLADE (Figure 4)

- Disconnect power and lower Presserfoot Leg.
- Lay machine on left side.
- Press and turn Thumbwheel "A" to move Blade to its lowest position.
- With Knife Key "B" turn Nut "C" counter clockwise to unlock blade.
- Raise Presserfoot Leg and slide Blade "D" downwards and out.
- Clean Inserts "E" with slot cleaning tool or bottom corner of blade.
- Slide new Blade up against Knife Locking Bolt.
- Holding lower part of Blade behind edge, push it firmly **up** against Bolt and **back** against Inserts.
- Tighten Nut "C."

Note: Use only genuine Maimin Blades with "Cut-Out" and T-shaped slot in shank for optimum performance and safe operation.

Always tighten Knife Locking Bolt and Nut before running machine to prevent damage to Crosshead A510 and Gibbs A513. Do not run sharpener without blade in machine or sharpener will jam.

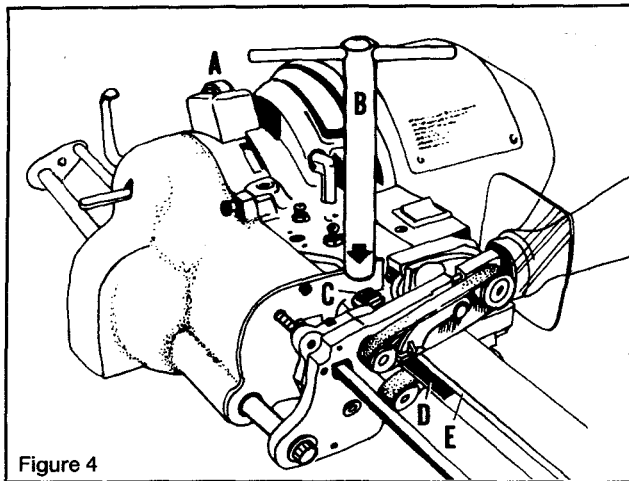

Figure 4

2.7 TO CHANGE BEVEL WIDTH ON BLADE (Figure 5)

- Run sharpener to lowest position, turn off motor, disconnect power.
- Loosen Screw "A."
- Insert Bevel Adjusting Tool "B" into Washer "C" and rotate Washer to increase or decrease blade bevel width. Note arrow on washer and edge width indicator on Band Plate Carrier (A374).
- Tighten Screw "A."
- Bevel on opposite side is adjusted in same manner.

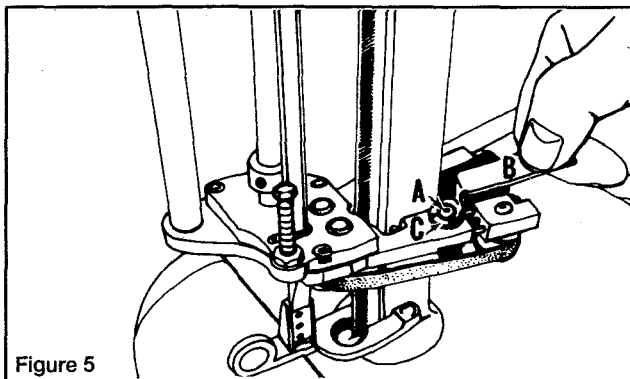

Figure 5

2.8 MAINTENANCE SCHEDULE

- Daily: Fill oil cups (A547). Use either Maimin Oil 22109 or quality "30 weight" oil (I.S.O. viscosity grade 220).
- Weekly:
 - Sharpener — run to lowest position, turn off motor, and blow out lint and dust with compressed air.
 - Motor — run motor, and point stream of compressed air into back of motor and side of front housing by fan to eject lint and dust.
- Every 500 hours of operation:
 - Sharpener — Remove Cap Screw (A367A) from top of Gear Case (A367) and squeeze in a small amount of Grease 22174 to coat gears.
 - Motor — Remove motor cover and, with compressed air, blow lint and dust from motor coils and armature.

2.9 TO REMOVE SHARPENER FROM MACHINE (Figure 6)

- Run sharpener to lowest position, turn off motor and disconnect power.
- Figure 6: Disengage Tripper Handle "A" by inserting handle of Knife Key "B" through hole in lower cover and pressing upwards until Tripper Handle snaps back to its "off" position.
- Remove Screw A390 holding Clamp Plate A394 against Band Plate Guide A393 and remove Guide and Plate.
- With 3/8" wrench remove 2 Nuts A344 and 2 Washers A343 holding Brake A342, and remove Brake.
- Remove Screw A316 holding Shafts Cover A315, and lift off Cover.
- Remove 3 Nuts A328 and 1 Nut 510B (at lower left rear corner of sharpener) which hold Drive Housing A327.
- Pull sharpener forward gently to remove.

2.10 TO ATTACH SHARPENER TO MACHINE

- Disconnect power.
- Wipe oil from outer diameter of Crank A505 and Pulley A303.
- Place sharpener onto 3 mounting Screws A521 on Front Housing.
- Add and tighten 3 Nuts A328 and Nut 510B on back of sharpener.

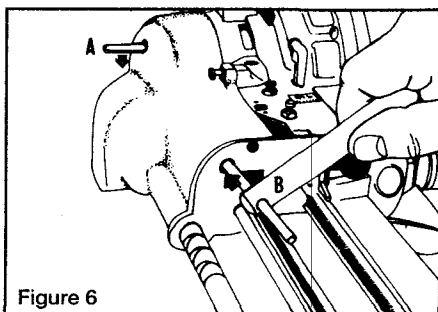

Figure 6

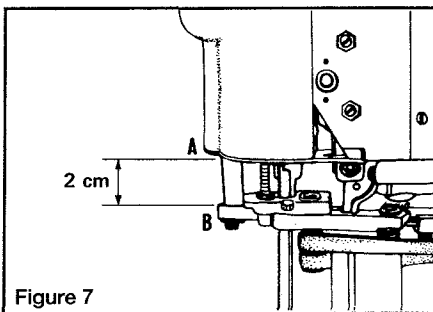

Figure 7

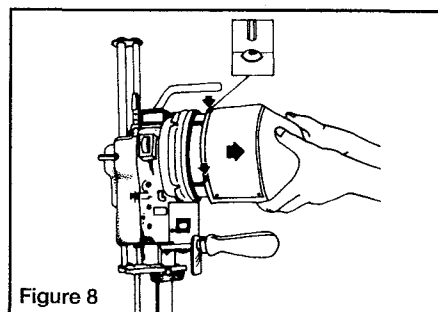

Figure 8

- Add Band Plate Guide A393 and Clamp Plate A394.
- Hold Guide against Standard A564 and tighten Screw A390.
- Lower Presserfoot Leg to Baseplate, connect power, and run sharpener to its top position. Disconnect power.
- Add Shafts Cover A315.
- Add Brake A342.

2.11 TO SET POSITION OF BAND PLATE CARRIER A374 (Figure 7)

- Run sharpener to highest position, turn off motor, and disconnect power.
- Figure 7: Measure distance between Cover "A" (A361) and top of Gear Case "B" (A367). Maximum distance is 25/32" (2 cm) when Screw A363 is adjusted properly.
- If distance is greater, loosen Nut A366 and lower Screw A363 a few turns. Tighten Nut, run sharpener, and measure again.
- FlexiBands A386 must not touch blade A574 when sharpener is at top position.

2.12 TO REMOVE MOTOR COVER A579 (Figure 8)

Disconnect Power. Loosen the 3 Screws A580, and slide Motor Cover off.

III. TROUBLE SHOOTING GUIDE

3.1 MACHINE TROUBLE SHOOTING

Symptom

Possible Cause

1. Bottom corner of blade breaks.

- Inserts (A558) badly worn.
- Knife strikes throat plate. If cutting hard materials, use wide slot throat plate.

2. Motor slow in reaching full speed.

- Low voltage or wrong voltage.
- Three phase:
 - Fuse out on one phase.
 - Ground wire incorrectly connected to machine.

3. Motor binds at one spot.

- Crosshead (A510) and Gibbs (A513) tight.
- Standard (A564) not in alignment with Crosshead (A510).
- Standard (A564) bent.

4. Motor becomes hot.

- Lint and dust inside Motor Cover (A579).
- Three phase: one phase not working.

5. Motor rotates wrong way.

- Three phase: Wiring incorrect. Change any two wires in Terminal Block (A522) or Connector (A525).

6. Motor does not start.

- Connector (A525) not firmly attached to Terminal Pins (A523).
- Switch (A550) defective.
- Starting Switch or Relay (A540) and/or Capacitor (A543) defective.
- Broken Jumper Wire. (Capacitor to Starting Switch or Relay)

7. Terminal Block and/or Connector becomes very hot.

- Inserts in Connector (A525) worn. Change Connector.
- Terminal Pins (A523) worn.

8. Machine does not roll freely on table.

- Surface of cutting table not smooth.
- Cushions (A561) in Roller Carriers compressed causing Baseplate (A560) to drag on table.

3.2 SHARPENER TROUBLE SHOOTING

Symptom

Possible Cause

- | Symptom | Possible Cause |
|--|--|
| 1. No bevel on one side of blade. | a) Broken Torsion Spring (A382, A388).
b) Band Plates (A381, A387) do not pivot freely.
c) Bands do not cross due to interference of Band Plates (A381, A387). |
| 2. Sharpener runs but bands do not rotate. | a) Square Shaft Gear (A336) broken.
b) Retaining Ring (A338) missing.
c) Clamp (A 364) out of position. |
| 3. Sharpener does not run but bands rotate. | a) Keeper Plate (A334) loose.
b) Boat (A333) worn.
c) Diamond Shaft (A356) worn. |
| 4. Sharpener does not run, bands do not rotate. | a) Presserfoot Leg (A403) not down completely.
b) Oil on Crank (A505) and/or Pulley (A303).
c) Retaining Ring (A320) missing.
d) Cluster Gear (A332) broken. |
| 5. Band cut off by blade. | a) Band Plate (A387) defective. |
| 6. Block (A397) falls off during band changing. | a) Retaining Ring (A398) missing. |
| 7. Block (A397) pivots, twisting band. | a) Stud (A383) broken. |
| 8. Sharpener runs slowly. | a) Oil on Crank (A505) and/or Pulley (A303).
b) Band Plate Guide (A393) too tight against Standard (A564).
c) Worn Pulley (A303).
d) Dirt in Cartridge (A318).
e) Bent Link (A346).
f) Worn Push Rod Cam (A314) and/or Tripper (A350).
g) Add Grease 22174 to Band Plate Carrier Gears (A374). |
| 9. Sharpener overruns top position. | a) Screw (A363) too low. |
| 10. Sharpener runs continuously. | a) Screw (A363) too low—less than 1" above Gear Case (A367). |
| 11. Sharpener runs only when Tripper Handle is held. | a) Pin (A348) broken.
b) Worn Push Rod Cam (A314) and/or Tripper (A350). |
| 12. Sharpener jams. | a) Sharpener run without knife in machine.
b) Boat (A333) broken.
c) Diamond Shaft (A356) bent.
d) Standard (A564) bent.
e) Nylon Washer (A360A) broken. |
| 13. Presserfoot Leg (A403) does not move freely. | a) Sharpener not at top position.
b) Dirt in Leg Guide (A354).
c) Brake (A342) too close to Pulley.
d) Presserfoot Leg (A403) bent. |
| 14. Presserfoot Leg does not hold. | a) Lock (A330) loose on Shaft (A325).
b) Presserfoot Handle Spring (A322) broken.
c) Teeth worn on Lock (A330).
d) Screw (A324) loose. |
| 15. Safety not working. | a) Leg Guide (A354) broken.
b) Link (A346) bent. |
| 16. Bands touch blade in top position. | a) Screw (A363) too high.
b) Cams (A515, A516) too high, broken or bent. |
| 17. Bevel very wide on both sides of blade. | a) Worn Band Plates (A387, A381).
b) Band Plate Guide (A393) too tight. |

MODEL A SHARPENER

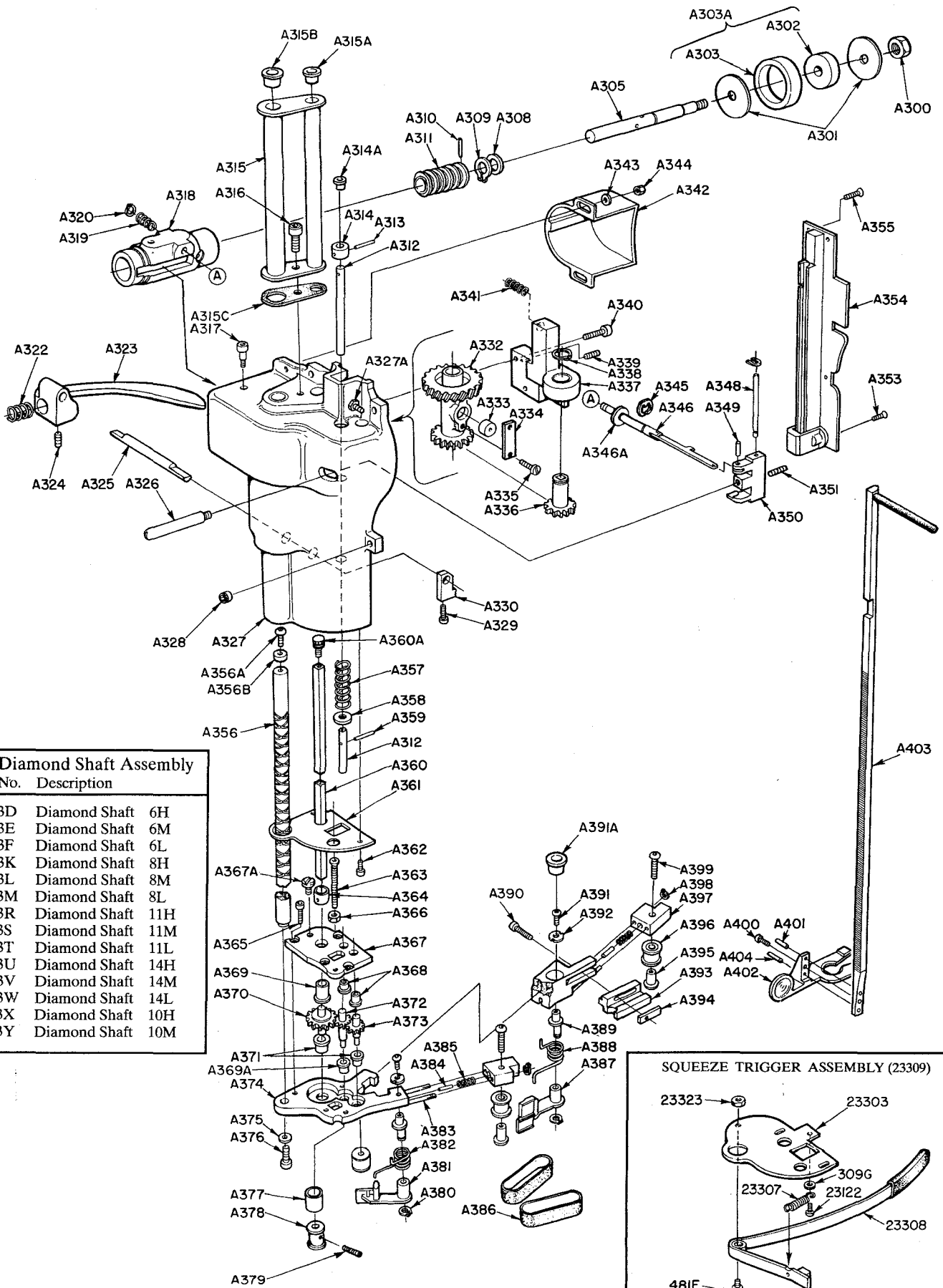

A356 Diamond Shaft Assembly

Part No.	Description
23093D	Diamond Shaft 6H
23093E	Diamond Shaft 6M
23093F	Diamond Shaft 6L
23093K	Diamond Shaft 8H
23093L	Diamond Shaft 8M
23093M	Diamond Shaft 8L
23093R	Diamond Shaft 11H
23093S	Diamond Shaft 11M
23093T	Diamond Shaft 11L
23093U	Diamond Shaft 14H
23093V	Diamond Shaft 14M
23093W	Diamond Shaft 14L
23093X	Diamond Shaft 10H
23093Y	Diamond Shaft 10M

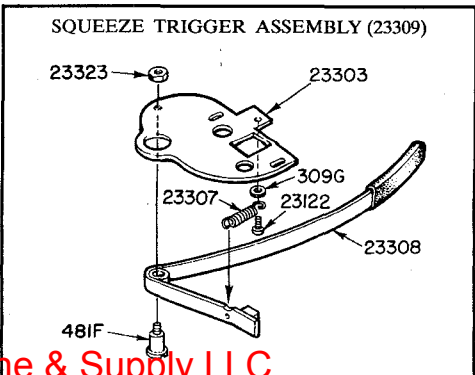

From the library of: Superior Sewing Machine & Supply LLC

PARTS LIST

KEY NO.	PART NO.	DESCRIPTION	KEY NO.	PART NO.	DESCRIPTION
A300	838N	Nut, 1/4-20 Hex	A360	23211A	Square Shaft , 6", 8"
A301	23298	Washer .250 X 1.500 X .06 (2)		232311C	Square Shaft, 10", 11"
A302	23299	Pulley Wheel (1)		23211D	Square Shaft, 14"
A303	1498	Pulley only	A360A	23320	Washer, Nylon, Square Shaft
A303A	23300	Pulley Wheel Assembly		23321	Screw, 6 X 3/8 Button Hd. Socket Cap
A305	23196	Worm Shaft	A361	23244	Cover
A308	839W	Washer, .32 X 1/2 X 1/32		23303	Cover, Squeeze Trigger Only
A309	23234	Retaining Ring, 5100-31	A362	23226	Screw, 6 X 1/4 Socket Hd. Cap (2)
A310	23066	Spring Pin, 7/64 X 1/2	A363	23290	Screw, 10 X 1-1/2 Fillister Hd.
A311	23067	Worm	A364	23212	Clamp w/23263
A312	23036	Push Rod		23263	Screw, 10 X 1/2 Slot Set Flat Pt.
A313	23267	Spring Pin, 1/16 X 3/8	A365	824T	Screw, 6 X 3/8 Socket Cap (4)
A314	23005	Cam	A366	836N	Kepnut, 10-32 Hex
A314A	402BL	Tapered Plug #181	A367	23275	Gear Case with Bushings
A315	23229E	Tapered Shafts Cover, 6", 8"	A367A	436S	Gear Case Grease Screw
	23229C	Shafts Cover, 10", 11"	A368	23086	Bearing, flanged .252 X .377 X 1/4
	23229D	Shafts Cover, 14"	A369	23091	Bearing, flanged .252 X .377 X 1/2
A315A	402BL	Tapered Plug #181	A369A	23091A	Bearing, Left Driven Gear
	402BQ	Tapered Plug #10 (for 23229E)		23210	Drive Gear
A315B	402BJ	Tapered Plug #241	A371	23086	Bearing, flanged .252 X .377 X 1/4
	402BW	Tapered Plug #16 (for 23229E)	A372	23208	Driven Gear, left
A315C	23302	Shafts Cover Gasket 10", 11", 14"	A373	23209	Driven Gear, right
A316	23056	Screw, 1/4 X 1/2 Socket Cap	A374	23276	Band Plate Carrier w/Bushings & Studs
	23332	Screw, 1/4 X 2 3/4 Socket Cap (for 23229E)	A375	23261	Washer, 3/16 X 1/2 X 3/64
	23334	Lockwasher, .263 X .365 X .078 (for 23229E)	A376	23084	Screw, 10 X 1/2 Socket Hd. Cap
A317	481F	Screw, 1/4 X 3/8 Shoulder (2)	A377	23098	Rubber Tire (2)
A318	23192	Cartridge w/Worm & Pulley	A378	23099	Drive Pulley (2)
A319	23017	Spring	A379	23097	Screw, 4 X 1/8 Soc. Set Flat Pt. (2)
A320	23219	Retaining Ring, 5555-23	A380	23227	Retaining Ring 5100-25 (2)
A322	492	Trigger Spring	A381	23165	Band Plate, right
A323	23047	Presserfoot Handle	A382	23110	Spring, Torsion, right
A324	490	Screw, 5/16 X 3/8 Set	A383	23115	Stud, 1/8 X 1-1/8 (4)
A325	23049	Shaft	A384	23116	Spring Pin, 3/32 X 1/4 (2)
A326	23053	Tripper Handle	A385	23117	Spring (2)
A327	23274	Drive Housing with Bushings	A386	1450	FlexiBand, Coarse — 100/box
A327A	510A	Screw, 10 X 1/2 Socket Set Cup		1451	FlexiBand, Medium — 100/box
	510B	Nut, 10-32 Hex		1452	FlexiBand, Fine — 100/box
A328	23252	Nut, 10-32 Socket (3)		1457	FlexiBand, Coarse — 500/box
A329	23271	Screw, 8 X 5/8 Socket Hd. Cap		1458	FlexiBand, Medium — 500/box
A330	23050	Lock		1459	FlexiBand, Fine — 500/box
A332	23189T	Cluster Gear	A387	23164	Band Plate, left
A333	23119A	Boat w/ Keeper Plate 23120	A388	23109	Spring, Torsion, left
A334	23120	Keeper Plate	A389	23223	Eccentric Stud (2)
A335	23259	Screw, 6 X 1/4 (2)	A390	23019	Screw, 6 X 5/8 Socket Cap
A336	23203	Square Shaft Gear	A391	802S	Screw, 6 X 3/16 Pan Hd. (2)
A337	23273	Gear Block with Bushings	A391A	402BJ	Tapered Plug #241
A338	1277	Retaining Ring, 5108-50	A392	23225	Washer (2)
	23330	Spacer	A393	23250	Band Plate Guide, 6", 8"
A339	23251	Screw, 10 X 3/4 Slot Set Flat Pt.		23272	Band Plate Guide, 10", 11"
A340	23019	Screw, 6 X 5/8 Socket Cap (2)		23282	Band Plate Guide, 14"
A341	23031	Spring	A394	23249	Clamp Plate
A342	23200	Brake	A395	23114	Stud, Idler Pulley (2)
A343	23007	Washer, 13/64 X 7/16 X 1/32 (2)	A396	23293	Pulley, Idler, w/Bushing (2)
A344	510B	Nut, 10-32 Hex (2)	A397	23111	Block (2)
A345	23016	Retaining Ring, 5144-25		23280	Block w/Idler Pulley, left
A346	23284	Link Assembly		23281	Block w/Idler Pulley, right
A346A	23289	Washer, .257 X 9/16 X 1/32	A398	23288	Retaining Ring, 5144-12 (2)
A348	23328	Tripper Pin w/840D	A399	23112	Screw, 8 X 1/2 Button Hd. (2)
	23011A	Tripper Pin Only	A400	23316	Lockwasher, #4 Split
	840D	Retaining Ring, 5555-12		23318	Screw, #4 X 3/8 Socket Head Cap
A349	23013	Spring Pin, 3/32 X 5/16		23319	Lock Nut, #4-40 Hex
A350	23190	Tripper	A401	23013	Spring Pin, 3/32 X 5/16
A351	23054	Screw, 6 X 1/8 Socket Set Cup	A402	23040	Presserfoot, 6", 8", 10", 11", 14"
A353	23258	Screw, 4 X 3/8	A403	23042B	Presserfoot Leg w/Lift 824A — 6"
A354	23217	Leg Guide w/Leg Keeper		23042D	Presserfoot Leg w/Lift 824A — 8"
	23325	Leg Guide Assy, Squeeze Trigger Only		23042H	Presserfoot Leg w/Lift 824A — 10"
A355	23122	Screw, 6 X 1/4 Loc-Wel Button Hd. Socket Cap (4)		23042F	Presserfoot Leg w/Lift 824A — 11"
	23093D-Y	Diamond Shaft Assy.(see Chart Pg.6)		23042G	Presserfoot Leg w/Lift 824A — 14"
A356A	23286	Screw, 10 X 1/2 Button Hd. Soc. Cap 14" Machines Only	A404	23013	Spring Pin, 3/32 X 5/16
	23287	Washer, Nylon, 14" Machines Only		SQUEEZE TRIGGER ASSEMBLY (23309)	
A356B	23287	Washer, Nylon, 14" Machines Only		23122	Screw, 6 X 1/4 Button Hd.
A357	23008	Spring		23303	Cover, Squeeze Trigger Only
A358	23007	Washer, 13/64 X 7/16 X 1/32		23307	Spring
A359	23267	Spring Pin, 1/16 X 3/8		23308	Squeeze Trigger Handle Assembly
				23323	Locknut 10-24
				309G	Brass Washer
				481F	Screw, 1/4 X 3/8 Shoulder

Always Give Machine **SERIAL NUMBER** When Ordering Parts.

Order By **PART NUMBER** — Not Key Number

From the library of Superior Sewing Machine & Supply LLC

MAIMIN®

THE CUTTER'S EDGE

SABRE 2000 AND 3000 MOTORS WITH STANDARD ASSEMBLIES

FOR MOTOR CODES AP1, AP2, AP3, AP4, AP8, AR1, AR2, AR3, AR4, AR8, ONLY

MOTOR CODES REFER TO FIRST 3 OR 4 DIGITS
IN SERIAL NO. BOX ON NAMEBAND AS SHOWN

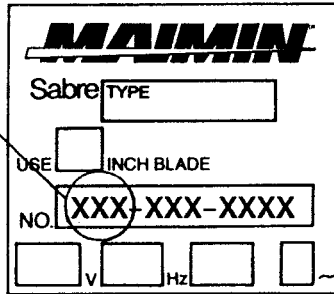

Sabre TYPE

USE INCH BLADE

NO. XXX-XXX-XXXX

V Hz

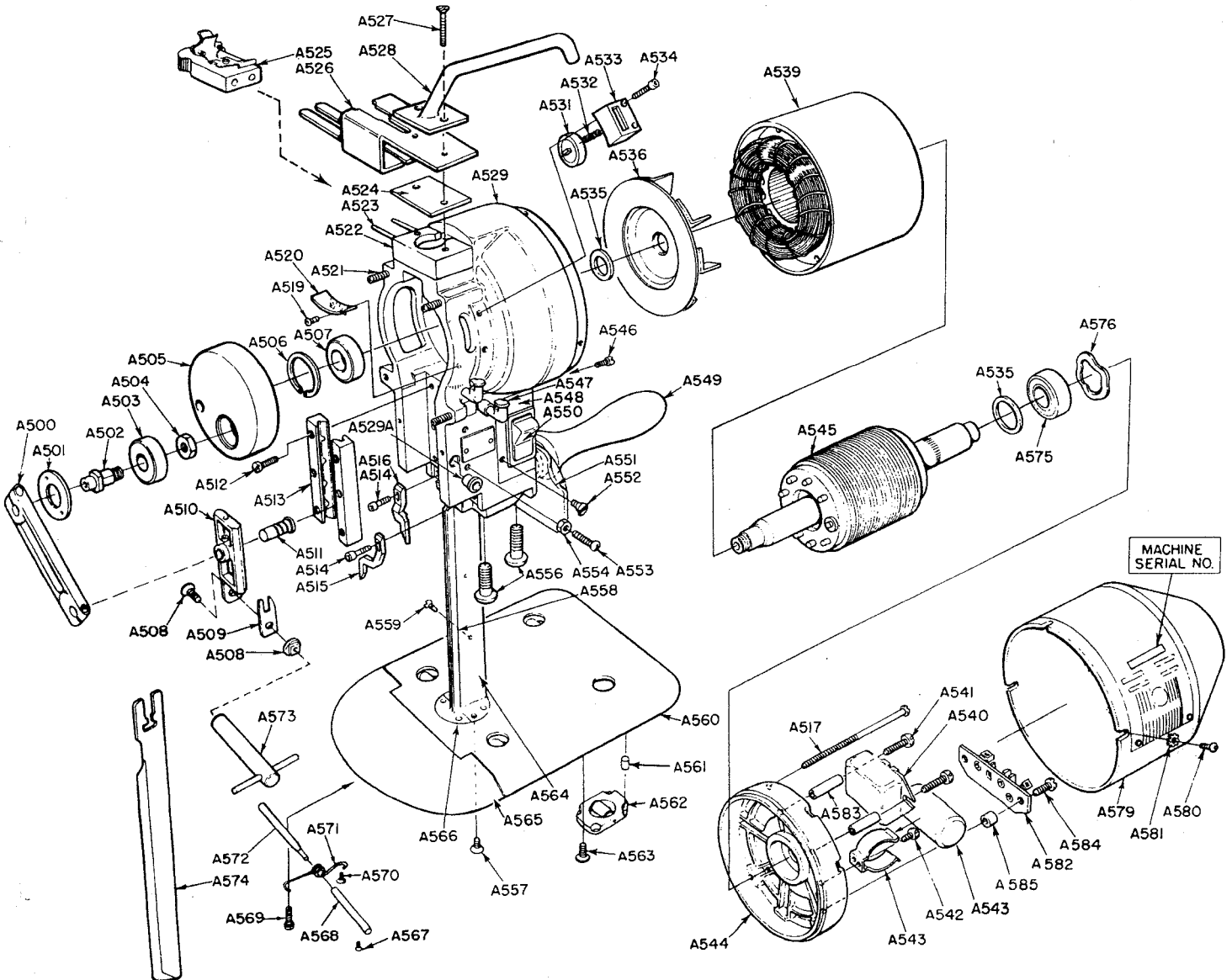

From the library of: Superior Sewing Machine & Supply LLC

H. MAIMIN CO., INC., P.O. BOX 549 — Route 341, Kent, Connecticut 06757, U.S.A.

PARTS LIST

KEY NO.	PART NO.		DESCRIPTION	KEY NO.	PART NO.		DESCRIPTION
	SABRE 2000	SABRE 3000			SABRE 2000	SABRE 3000	
A500	412A	412A	Connecting Rod — H		—	15282	Armature Assembly, Sabre 3000
	412B	412B	Connecting Rod — M	A546	441S	441S	Screw, 6 x 5/16 Fillister Hd. (2)
	412C	412C	Connecting Rod — L	A547	402BD	402BD	Oil Cup
A501	413W	413W	Bearing Lock	A548	402B	402B	Oil Cup Assembly with Tube
A502	415	415	Crank Pin	A549	466G	466G	Cover, Switch Box
A503	414	414	Crank Bearing	A550	464P	464P	Contoured Handle w/Bushing
A504	415N	415N	Crank Nut	A551	443	443	Switch
A505	413BX	413BX	Crank w/413W, 414, 415-H	A551	464R	464R	Shield
	413CX	413CX	Crank w/413W, 414, 415-M	A552	818S	818S	Screw, 6 x 1/4 Flat Hd.
	413DX	413DX	Crank w/413W, 414, 415-L	A553	410	410	Screw, 8 x 1/2 Fillister Hd. (2)
A506	404E	404E	Retaining Ring	A554	410N	410N	Nut (2)
A507	403	403	Bearing #203	A556	425A	425A	Bolt, 3/8 x 3/4 Button Hd. (3)
A508	416	416	Knife Bolt & Nut	A557	427S	427S	Screw, 10 x 3/8 Flat Hd. Soc. (6)
A509	411A	411A	T-Slot Lock	A558	428B	428B	Insert for Standard — 8"
A510	411	411	Crosshead w/411P		428D	428D	Insert for Standard — 6"
A511	411P	411P	Wrist Pin		428G	428G	Insert for Standard — 10"
A512	409A	409A	Screw, 8 x 3/4 Fillister Hd. (6)		428H	428H	Insert for Standard — 11"
A513	409C	409C	Gibbs, pair		428M	428M	Insert for Standard — 14"
A514	23226	23226	Screw, 6 x 1/4 Socket Hd. (2)	A559	428T	428T	Insert Screw
A515	23151	23151	Cam, Right	A560	429C	429C	Baseplate with Rollers & Lip
A516	23152	23152	Cam, Left		440L	440L	Swivel Baseplate with Rollers & Lip
A517	419U	—	Motor Bolt, 8-32 x 4 1/2 Hex Washer Hd. (4)	A561	436K	436K	Rubber Cushion
	—	419F	Motor Bolt, 8-32 x 4 3/4 Hex Washer Hd. (4)	A562	436	436	Roller Carrier Assembly
A519	802S	802S	Screw, 6 x 3/16 Binding Hd. (2)		440M	440M	Swivel Roller Assembly (Rear)
A520	402L	402L	Oil Guard		440J	440J	Swivel Adaptor Ring
A521	23230	23230	Screw, 10 x 7/8 Flat Pt. Soc. Set (3)	A563	436S	436S	Screw, 10 x 5/32 M Hd.
A522	405	405	Terminal Block with Pins	A564	424BS	424BS	Standard — 8"
A523	406	406	Terminal Pin (2)		424DS	424DS	Standard — 6"
A524	405PE	405PE	Fibre Cover		424GS	424GS	Standard — 10"
A525	458B	458B	Current Connector		424HS	424HS	Standard — 11"
A526	458K	458K	Ground Shield		424MS	424MS	Standard — 14"
A527	408	408	Screw, 8 x 1 1/8 Flat Hd.	A565	430	430	Lip
A528	407D	407D	Top Handle	A566	426A	426A	Throat Plate — 6", 8"
A529	402AB	402AB	Front Housing w/23230 (3)		426B	426B	Throat Plate — 10", 11", 14"
A529A	402BG	402BG	Tapered Plug #7-S		426C	426C	Throat Plate, Wide Slot — 6", 8", 10"
A531	468J	468J	Thumbwheel w/Shaft		426E	426E	V Throat Plate — 6", 8"
A532	468C	468C	Spring	A567	426F	426F	V Throat Plate — 10", 11", 14"
A533	468D	468D	Thumbwheel Support		436S	436S	Screw, 10 x 5/32 M Hd.
	468A	468A	Thumbwheel Assembly	A568	431B	431B	Shaft, Short
A534	468S	468S	Screw, 6 x 7/8 Socket Hd. (2)	A569	802S	802S	Screw, 6 x 3/16 Binding Hd.
A535	497P	497P	Support Washer	A570	802S	802S	Screw, 6 x 3/16 Binding Hd.
A536	400K	400K	Fan	A571	433A	433A	Spring, Lip
A539	15260	—	Shell & Field Assembly, SABRE 2000	A572	431A	431A	Shaft, Long
	—	15283	Shell & Field Assembly, SABRE 3000	A573	457	457	Knife Key
A540	365A	—	Starting Switch, SABRE 2000	A574	—	—	Blade (see back cover)
	—	365J	Starting Switch, SABRE 3000	A575	403	403	Bearing #203
A541	15264	15264	Screw, 8-32 x 1 1/4 Phillips Pan Hd. (2)	A576	15195	15195	Loading Spring
	15288	15288	Washer 3/8 x .175 x .035 (2)	A579	302QB	—	Motor Cover, SABRE 2000
A542	15266	15266	Screw, 8-32 x 3/8 Phillips Pan Hd.		—	302QM	Motor Cover, SABRE 3000
A543	15262	15262	Capacitor Clamp	A580	23122	23122	Screw, 6 x 1/4 Button Hd. (3)
	15079	—	Capacitor 161 mfd — Sabre 2000	A581	309F	309F	Lockwasher, #6 (3)
	—	15076	Capacitor 270 mfd — Sabre 3000	A582	483G	483G	Terminal Strip
A544	15261	15261	Back Housing	A583	15265	15265	Spacer, Starting Switch (2)
A545	15277	—	Armature Assembly, Sabre 2000	A584	15267	15267	Screw, 8-32 x 5/8 Phillips Pan Hd. (2)
				A585	15268	15268	Spacer, Terminal Strip (2)

Always Give Machine SERIAL NUMBER When Ordering Parts.



Order By PART NUMBER — Not Key Number

H. MAIMIN CO., INC.

P.O. BOX 549 — ROUTE 341, KENT, CONNECTICUT 06757, U.S.A.

From the Inventory of Superior Sewing Machine & Supply LLC

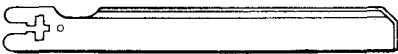
BLADES AVAILABLE

Shape & Application	Grade	Quantity	Size & Part Number				
			6"	8"	10"	11"	14"
REGULAR  For general purpose cutting	BK	Dozen	30012	30014	30016	—	—
LONG  For hard or loosely woven materials, and general purpose cutting	ZKL	Each Dozen	30084 30085	30088 30089	30098 30099	30092 30093	30094 30095
TEFLON COATED  For synthetics	ZKL	Each Dozen	30100 30101	30102 30103	30106 30107	— —	— —
WAVE  For synthetics and plastics	ZK	Each Dozen	30174 30175	30178 30179	— —	— —	— —

Note: There is a different part number for single blades and boxes of one dozen (12).

PLEASE ORDER BY PART NUMBER

H. MAIMIN CO., INC.

P.O. BOX 549 — ROUTE 341, KENT, CONNECTICUT 06757, U.S.A.

PHONE: (203) 927-4601 FAX: (203) 927-4703

USA: (800) 243-4645

From the library of: Superior Sewing Machine & Supply LLC